

Clipper Office Tester



- Accurate, dependable performance for small lot cleaning, testing, or sampling
- Tabletop design is small, yet accurate
- Compact and easy to move
- Used in seed plants for sampling large lots
- Popular with vegetable and flower growers and in seed stores for specialized cleaning, grading, and sizing
- Many laboratory uses
- Scalper and sifter screens are standard with over 150 sizes to choose from
- Shoe uses two 10" x 15" screens, one for the top and the other for the lower separation area
- Optional removable catchall performs as an air screening receptacle with removable tray
- Powerful bottom blast fan driven by a three-step pulley
- Adjustable slide on the air intake openings provide intermediate air regulation



SINCE 1869

1440 SOUTH ADAMS STREET, BLUFFTON, IN 46714 USA (260) 824-3400 (800) 248-8318 FAX (260) 824-5463

atferrell@atferrell.com

www.atferrell.com

Typical Commodity Flow

- (1) The commodity is fed to the hopper and is spread evenly across the full width of the top screen.
- (2) The product then moves across the top screen, which has openings larger than the product itself. The large foreign material is "scalped" off while the good product falls through the screen.
- (3) The bottom screen can either sift or scalp. To set up for sifting, the bottom screen openings must be smaller than the commodity being cleaned. Trash, weed seeds and splits drop through the bottom screen while the good product passes over it. (This is the flow shown in the diagram at the left). When scalping, the screen openings must be larger than the product itself. The large foreign material is "scalped" off while the good product falls through the screen.
- (4) Next, the product is routed through a column of air from the bottom blast fan. This blast of air effectively removes any lightweight trash and dust that may have remained after screening.
- (5) Good, clean product is discharged at the bottom of the air chamber into a clean seed box.

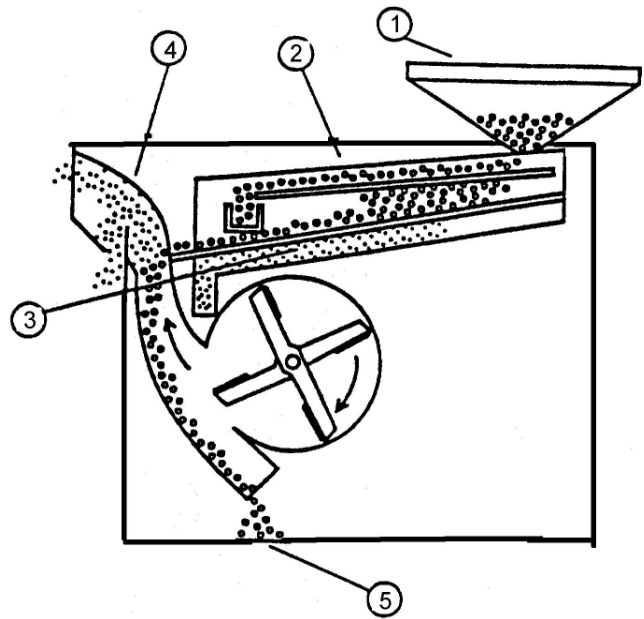

Dimensions (Inches)

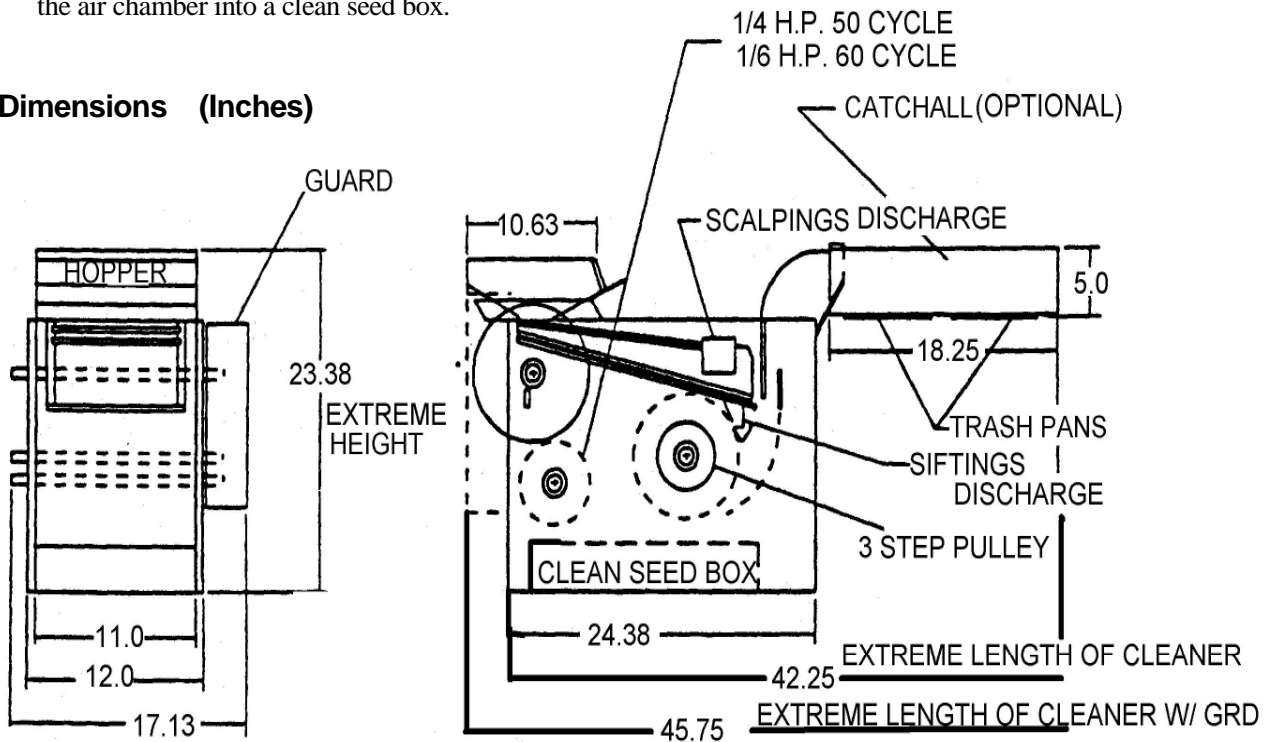

SINCE 1869

1440 SOUTH ADAMS STREET, BLUFFTON, IN 46714 USA (260) 824-3400 (800) 248-8318 FAX (260) 824-5463
www.atferrell.com info@atferrell.com